



Technical Data Sheet



DOWSIL™ 791T Weatherproofing Sealant Transparent

One-part silicone sealant

APPLICATIONS

- DOWSIL™ 791T Weatherproofing Sealant Transparent is specifically formulated for the sealing of expansion joints in curtain walling facades, building facades and other structures. It is also suitable for the sealing of connection joints between floors and walls, stairs and other building connections.

TYPICAL PROPERTIES

Specification Writers: These values are not intended for use in preparing specifications.

FEATURES

- Will accommodate up to 50% joint movement
- Excellent unprimed adhesion to a wide variety of construction materials such as concrete, stone, masonry, brick, wood, steel, glass, glazed surfaces, painted or varnished wood and ceramics
- Ideal sealant for expansion, connection and other movement joints as its low modulus allows high movement but generates relatively low stress at the adhesion interface
- Conforms to ISO 11600-F&G 25LM

BENEFITS

- Compatible with typical PVB foils. Project-specific testing available upon request
- Easy, conventional tooling
- Excellent resistance to weathering
- Good recovery after extension and compression
- High resistance to ozone, ultra violet radiation
- Excellent stability through wide temperature range: -50°C to 150°C

CTM ¹	Property	Unit	Value
	Cure system		Oxime
	Application temperature	°C	+5 to +40
097B	Specific gravity	g/ml	1.03
364C	Extrusion	g/minute	100
155A	Penetration	1/10 mm	125
098	Skin-over time (23°C, 50% R.H.)	minutes	10–15
095A	Tack-free time (23°C, 50% R.H.)	minutes	15–50
663A	Cure rate (23°C, 50% R.H.)		
	1 day	mm	3.0
	3 days	mm	4.0
	2 mm thickness S2 dumb-bells (ASTM² D412)		
137A	E-Modulus 100%		0.30
137A	Tensile strength		1.3
137A	Elongation at break		575
	12 x 12 x 50 mm size T.A. joint (ISO³ 8339/DIN⁴ 52455-2)		
677	E-Modulus 100%	MPa	0.32
677	Tensile strength		0.5
677	Elongation at break		300
677	Failure mode	%	100
		Cohesive Failure	
99E	Hardness	Shore A	15
0677	Elastic recovery (ISO 7389)	%	> 90

The data presented have been obtained with unpigmented product.

¹CTM: Corporate Test Method, copies of CTMs are available on request.

²ASTM: American Society for Testing and Materials.

³ISO: International Standardization Organization.

⁴DIN: Deutsche Industrie Norm.

DESCRIPTION

DOWSIL 791T Weatherproofing Sealant is a premium, one-part, easy to use, neutral curing transparent silicone sealant. It has excellent weatherability and flexibility. This low modulus silicone sealant has outstanding primerless adhesion to a wide variety of non-porous & porous substrates. Performance related to mildew and fungus resistance has been tested in accordance with the ISO-norm 846.

TECHNICAL SPECIFICATIONS AND STANDARDS

ISO 11600-F+G-25LM
ISO 846

HOW TO USE

Surface preparation

Surfaces must be clean, dry and free from grease, dust and frost. Non-porous surfaces such as aluminum, glass, etc., should be cleaned with a suitable solvent for the substrate such as DOWSIL™ R-40 Universal Cleaner, isopropanol, etc. Porous surfaces such as concrete, brick, mortar, etc., should be mechanically cleaned using a steel brush, sanding disk, etc.

When using any solvent, always provide adequate ventilation. Avoid heat, sparks and open flames. Always observe and follow all precautions listed on solvent container labels.

DOWSIL 791T Weatherproofing Sealant should not be applied to surfaces below 5°C or above 40°C as the adhesion of the sealant to the surface may be affected.

Masking

It is recommended that the areas adjacent to the sealant joint are masked with an appropriate tape to prevent contamination of the substrate and to ensure a neat sealant line. Masking tape should be removed immediately after tooling and before the sealant starts to form a skin.

Priming

DOWSIL™ Construction Primer P is required for porous substrates.

Back-up materials

Closed cell polyethylene backer rods are recommended as a joint back up material.

Tooling

The applied sealant should be tooled within 5 to 10 minutes of application to ensure good contact between the sealant and the substrate. Tooling of the sealant also gives a smooth professional finish.

HANDLING

PRECAUTIONS

PRODUCT SAFETY INFORMATION REQUIRED FOR SAFE USE IS NOT INCLUDED IN THIS DOCUMENT. BEFORE HANDLING, READ PRODUCT AND SAFETY DATA SHEETS AND CONTAINER LABELS FOR SAFE USE, PHYSICAL AND HEALTH HAZARD INFORMATION. THE SAFETY DATA SHEET IS AVAILABLE ON THE DOW WEBSITE AT WWW.CONSUMER.DOW.COM, OR FROM YOUR DOW SALES APPLICATION ENGINEER, OR DISTRIBUTOR, OR BY CALLING DOW CUSTOMER SERVICE.

USABLE LIFE AND STORAGE

When stored in cool, dry conditions below 30°C in the original unopened containers, DOWSIL 791T Weatherproofing Sealant has a usable life of 12 months from the date of production.

PACKAGING INFORMATION

DOWSIL 791T Weatherproofing Sealant is available in 310 ml cartridges (12 per box).

LIMITATIONS

DOWSIL 791T Weatherproofing Sealant should not be used against substrates that bleed oils, plasticizers or solvents. It is not recommended for use against certain plastics, generally of the flexible, plasticized type.

In situations where bleeding or staining is a risk, please contact us for technical assistance.

DOWSIL 791T Weatherproofing Sealant has been generally tested for compatibility with some typical PVB foils. However, project-specific testing is strongly recommended with contact materials before any use.

This product is neither tested nor represented as suitable for medical or pharmaceutical uses.

HEALTH AND ENVIRONMENTAL INFORMATION

To support customers in their product safety needs, Dow has an extensive Product Stewardship organization and a team of product safety and regulatory compliance specialists available in each area.

For further information, please see our website, www.consumer.dow.com or consult your local Dow representative.

UNRESTRICTED – May be shared with anyone

®™Trademark of The Dow Chemical Company (“Dow”) or an affiliated company of Dow

DOWSIL™ 791T Weatherproofing Sealant Transparent

© 2017 The Dow Chemical Company. All rights reserved.

**LIMITED WARRANTY
INFORMATION – PLEASE
READ CAREFULLY**

The information contained herein is offered in good faith and is believed to be accurate. However, because conditions and methods of use of our products are beyond our control, this information should not be used in substitution for customer's tests to ensure that our products are safe, effective, and fully satisfactory for the intended end use. Suggestions of use shall not be taken as inducements to infringe any patent.

Dow's sole warranty is that our products will meet the sales specifications in effect at the time of shipment.

Your exclusive remedy for breach of such warranty is limited to refund of purchase price or replacement of any product shown to be other than as warranted.

**TO THE FULLEST EXTENT
PERMITTED BY APPLICABLE
LAW, DOW SPECIFICALLY
DISCLAIMS ANY OTHER
EXPRESS OR IMPLIED
WARRANTY OF FITNESS FOR A
PARTICULAR PURPOSE OR
MERCHANTABILITY.**

**DOW DISCLAIMS LIABILITY
FOR ANY INCIDENTAL OR
CONSEQUENTIAL DAMAGES.**

www.consumer.dow.com

Application Examples for DOWSIL 791T Weatherproofing Sealant Transparent

Figure 1: Sloped roof glazing with butt joint, mechanically held on 2 sides.

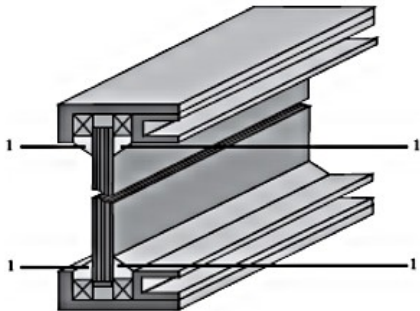
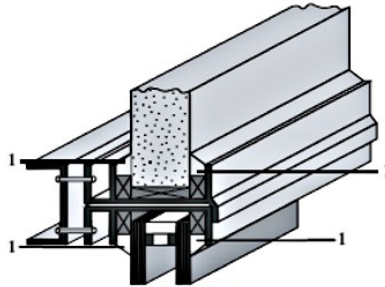

Figure 3: Design incorporating granite or reconstituted stone panels.



Designs possible with single or insulated units as shown, in sloped or vertical configurations. (Unit dimensions and glass thickness should be designed to limit deflections to comply with prevailing standards or design limits).

Figure 4: Design incorporating metallic panels

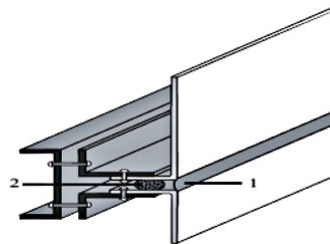

Figure 2:

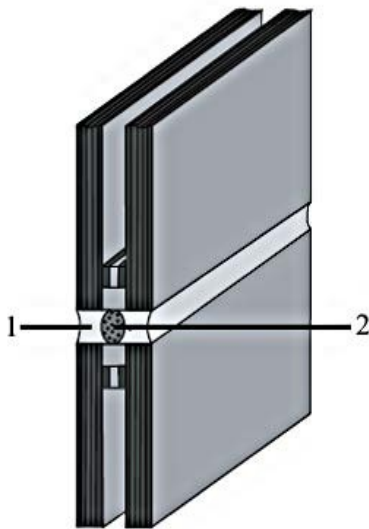
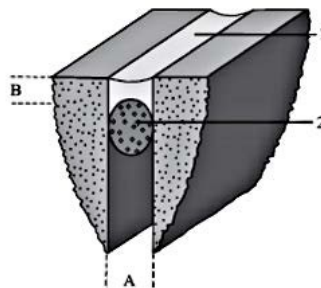

Figure 5: Recommended design for moving joints. Ratio of A:B should be 2:1.



Legend

1. DOWSIL 791T Weatherproofing Sealant Transparent
2. Backer rod
 - A. Joint sealant width
 - B. Joint sealant depth

